

# CONTINUO

DECORATIVE COATING WITH CEMENT EFFECT FOR  
FLOORING AND WALLS

**APPLICATION TECHNICAL MANUAL**



# CONTENTS

1_DESCRIPTION.....	PAGE 3
2_AREAS OF APPLICATION.....	PAGE 4
3_COMPONENTS OF THE SYSTEMS.....	PAGE 6
• 3.1 PRODUCTS FOR SURFACE PREPARATION.....	Page 6
• 3.2 DECORATIVE PRODUCTS.....	Page 7
• 3.3 PRIMING PRODUCTS.....	Page 7
• 3.4 TOP PROTECTION PRODUCTS.....	Page 8
• 3.5 COMPLEMENTARY PRODUCTS.....	Page 8
4_DECORATIVE EFFECTS.....	PAGE 9
• 4.1 CONTINUO EFFETTO MINIMAL / EFFETTO STYLE.....	Page 10
• 4.2 CONTINUO WOOD EFFECT.....	Page 10
• 4.3 CONTINUO MARBLE EFFECT.....	Page 12
• 4.4 CONTINUO OXIDIZED EFFECT.....	Page 14
5_SYSTEMS APPLICATION.....	PAGE 17
• 5.1 AREAS AND ENVIRONMENTS.....	Page 18
6_PRODUCTS PREPARATION AND USE, AND TECHNICAL CHARACTERISTICS.....	PAGE 28
• 6.1 THE CONTINUO PRODUCTS .....	Pag.28
• 6.2 COMPLEMENTARY PRODUCTS.....	Pag.36
7_INDICATIVE COVERING CAPACITIES .....	PAGE 37
8_TECHNICAL SPECIFICATIONS AND USE LIMITS.....	PAGE 37
• 8.1 BACKGROUND SUPPORT.....	Page 37
• 8.2 CONCRETE SURFACES .....	Page 38
• 8.3 CERAMIC, PORCELAIN, STONE, MOSAIC AND SIMILAR TILED SURFACE .....	Page 38
• 8.4 SCREEDS WHERE THERE IS UNDERFLOOR HEATING/COOLING .....	Page 39
• 8.5 TRADITIONAL SCREEDS.....	Page 39
• 8.6 FLATNESS .....	Page 40
• 8.7 JOINTS.....	Page 40
• 8.8 SHOWER CUBICLES.....	Page 40
• 8.9 SURFACE SLIPPERINESS.....	Page 41
• 8.10 SURFACES & FURNISHINGS .....	Page 42
9_SITE ENVIRONMENTAL CONDITIONS .....	PAG.43
• 9.1 CONTINUO PRODUCTS STORAGE.....	Page 44
10_CLEANING AND MAINTENANCE OF THE BACKGROUND SURFACES .....	PAGE 44

## 1\_DESCRIPTION

**CONTINUO** is a multilayer decorative covering solution that can be applied onto floors, walls, furniture and furnishing accessories. It has been created to meet the multiple technical and aesthetic needs of contemporary architecture in the home or commercial sector.

**CONTINUO** is made up of several products to meet the many market needs, and to make the system technically advanced. The finishes give a contemporary look thanks to colours and textures that confer a new look to residential, working and commercial interiors.

It can be applied non-invasively, without demolition and reconstruction using up only a few millimetres. It is less than 3 mm thick and normally weighs less than 3 kg/m<sup>2</sup>. The system allows a new surface to be laid over the existing one, thus giving alternative solutions that can be optimized according to the available thickness:

- Total system thickness less than 3 mm
- Total system thickness greater than 3 mm

The **CONTINUO** products are based on the specific properties of the individual mineral and organic products, which can be easily used and modified as required.

When used properly by following the recommendations in this user manual, the products ensure the best results with respect to the site's needs, and the achievement of specific performance, ensuring the work has a long lifetime.

The performance and specific resistances of the **CONTINUO** systems are modular, and designed to meet different styles and trends.

Before laying **CONTINUO** systems on the ground in areas with underfloor heating/cooling, please refer to the manual, section **8.4 Screeds where there is underfloor heating/cooling**.

Please be aware that the specific performance is closely linked to the correct use and application of the individual products. Please consult the technical documentation (manuals, technical and safety documentation) on the web portal [www.san-marco.com](http://www.san-marco.com), for further technical information. To request a copy of the test reports, please contact the technical service.

**The CONTINUO System** is classified A+ according to the French ministerial decree for air quality in interior environments.

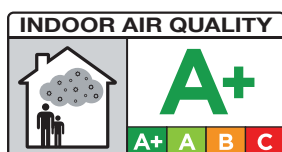

## 2\_AREAS OF APPLICATION



**LIVING**

The **CONTINUO LIVING** system is dedicated to the needs of typical residential surfaces and environments such as kitchens, living rooms etc. It is not intended for bathrooms, laundries and garages.



**ACTIVITY**

The **CONTINUO ACTIVITY** system is intended for the needs of residential surfaces and environments where a good resistance against water, wear-and-tear and stains from food, drink and household substances, is required. Suitable for use in bathrooms, laundries and kitchens.

### Areas identified as interior areas with average or intensive use are:



**STUDIO**

The **CONTINUO STUDIO** solution is dedicated to the needs of residential surfaces and contexts, or for studios and offices. Recommended for places that require a medium resistance to pedestrian traffic.



**LOUNGE**

The **CONTINUO LOUNGE** System is intended to meet the needs of commercial areas and contexts used for public establishments with medium traffic intensity such as bars, restaurants, beauty areas, accommodation facilities, specialized private services (clinics, schools and training centres), and offices with medium foot-traffic and/or wheelchair passage. This system is specific for where finishes are required with ease of cleaning and good resistance to water, food/drink stains and substances commonly used in catering. It is not for where there are strongly acidic or alkaline substances.

The **CONTINUO LOUNGE** solution does not include areas subject to other traffic (factories, workshops, warehouses, wholesale facilities, supermarkets etc.).

### Areas identified as protected outdoor areas with medium use are:



**PATIO**

The **CONTINUO PATIO** system is intended for protected exterior surfaces of residential contexts. Surfaces partly exposed to weathering such as patios/terraces and areas around homes. Not included are areas around swimming pools and car-parking areas.

### Areas identified as interior areas with average intensity use are:



**FURNITURE**

The **CONTINUO FURNITURE** solution is for customizing furniture, complements and other items in private or commercial settings. Non included are surfaces used for intensive professional purposes (kitchens and restaurants).

Every CONTINUO 'system' has a technical Annex containing the technical specifications on area of use. For further information or to request a copy of the test reports, please contact our technical service.

**After appropriately preparing the surfaces, the CONTINUO systems can be applied onto:**

- Concrete
- Screeds (sand and cement screeds, or sand and binder specific for screeds, ready-made screeds, screeds on heated floors, and self-levelling sand and cement screeds)
- Surfaces tiled with ceramic, porcelain, mosaic
- Surfaces with existing epoxy or polyurethane coatings
- Surfaces in natural and reconstructed stone
- Various mineral conglomerates, provided they are absorbent
- New and old plasters with aqueous binders
- Decorative organic or mineral coatings
- Surfaces in plaster and plasterboard

**The CONTINUO systems cannot be applied onto:**

- Horizontal and vertical backgrounds that do not offer the necessary guarantees in terms of adhesion and dimensional stability.
- For screeds based on calcium sulphate CA or magnesite MA, or other types, please contact the technical office of San Marco Group S.p.A.
- Traditional parquet
- Linoleum
- Wood prefinished items
- Surfaces in painted and non-painted metal
- Surfaces in glass or glass-block
- Damp surfaces or where there is rising damp
- Not apply on sanitary ware of ceramic, resin and similar.



**The CONTINUO systems cannot be applied in loading and unloading areas where the use of trolleys, pallet trucks, fork-lifts or similar is required or foreseen.**

## 3\_COMPONENTS OF THE SYSTEMS

CONTINUO is made up of 4 product categories which, although they have different functions and natures, are essential for obtaining an aesthetically-pleasing and high-performance result. Indeed, the materials are formulated to work in close synergy with each other and are easy to use and modify if necessary, according to the needs of use, and to achieve specific performances to ensure the best durability of the work.

For this reason, the products must be correctly used according to the procedures given in section 5: Application of the products.

Every product family is organized according to the technical-performance characteristics of:

- surface preparation
- decoration
- priming
- final protection

### 3.1 PRODUCTS FOR SURFACE PREPARATION

- **CONTINUO LEVEL\_ZERO:** is a cement-based leveller, with controlled shrinkage for indoor use, made up of natural sands, binders and special additives that give perfect adhesion to the surface to be decorated, and excellent workability. LEVEL\_ZERO can be applied in thicknesses ranging from 3 mm to 20 mm per coat.



**If necessary, you can overlay with a second coat of CONTINUO LEVEL\_ZERO. Before applying a second coat of the leveller LEVEL\_ZERO, to avoid small craters from forming later on the surface, apply a layer of Primer LINK, a transparent, water-thinnable, two-component epoxy product. Before use, dilute with water of 200% in weight.**

For the correct use of the products, please refer to the methods of use indicated in section 5 Product application. LEVEL\_ZERO gives off an extremely low level of volatile organic substances.

- **CONTINUO BASE:** ready-mixed, cement-based, one-component powder skimming coat for indoor use. Simply mixing CONTINUO BASE with water creates a cement mortar of medium hardening time for maximum thicknesses of 1.5 mm. BASE gives off an extremely low level of volatile organic substances.
- **CONTINUO EPOXY COMBO:** is a two-component epoxy binder to be used as a modifier with the CONTINUO BASE skim coat. The epoxy mortar produced in this way makes it possible to create a tri-component epoxy-concrete skim coat offering high mechanical resistance, adhesion, shrinkage-free, and suitable for all building materials, and specifically for the CONTINUO systems. The epoxy mortar produced in this way will be applied to the previously-cleaned surface. EPOXY COMBO cannot be used as a modifier for products other than CONTINUO BASE. EPOXY COMBO gives off an extremely low level of volatile organic substances.



**When preparing the base coat of the systems, you can use a fibre-glass mesh with anti-alkali treatment  $>70 < 90 \text{ g/m}^2$  with a mesh width between 3.5 and 4.5 mm (see section 5 PRODUCT APPLICATION).**

### 3.2 DECORATIVE PRODUCTS

- **CONTINUO DECO:** is a decorative two-component organic-mineral spreadable coating that can be coloured using the Marcromie tintometric system. The simple on-site mixing of CONTINUO DECO A (decorative organic putty) with CONTINUO DECO B (premixed with suitably-modified mineral components) allows you to add effects and colour to surfaces. Easy to use, it is versatile in its applications, offering a wide range of aesthetic effects: characterized by a flat or slightly troweled effect, using the right balance of tone and saturation between all colours that can easily be made with the Marcromie tinting system. The special formulation of CONTINUO DECO offers decorators the possibility of creating the CONTINUO textures or of inventing new effects depending on their imagination and ability. CONTINUO DECO creates surfaces with good surface hardness suitable for decorating horizontal surfaces that can be walked on, and vertical surfaces in residential and commercial areas used for public businesses with medium traffic or intensity. CONTINUO DECO is a decorative product with very low emissions of volatile organic substances.

### 3.3 PRIMING PRODUCTS

- **CONTINUO LINK:** is a primer that enhances the uniformity of the colour and attenuates the effect of the spatula, allowing you to obtain decorative finishes having a minimal and 'monolithic' appearance. For even-looking surfaces with a flat effect, with little shading and colour-tone nuances. CONTINUO LINK is a two-component, water-thinnable, transparent epoxy primer with a high penetrating and consolidating power, characterized by low yellowing, which creates a surface particularly suitable for the CONTINUO TOP and TOP ART paints to film correctly and develop maximum performance. When used on particularly pale surfaces, slight lightening may occur over time. CONTINUO LINK is also recommended as a primer for the PAVIFLOOR epoxy finish, and can also be used to consolidate and protect horizontal and vertical concrete surfaces, improving the anti-dust function and reducing the absorption of water and oils. CONTINUO LINK has very low emissions of volatile organic substances.
- **CONTINUO LINK ART:** maintains a clear and well-defined effect of the decorative trowel effect while maintaining the soft and shaded colour tones. CONTINUO LINK ART is a two-component epoxy-resin-based primer in water dispersion and a special hardener that gives rapid drying and very low emissions of volatile organic substances. With its high compatibility, it can be coloured or mixed with decorative finishes, creating original semi-covering versions that can further customize the aesthetics of the CONTINUO systems, creating a surface ideal for the TOP and TOP ART paints to film correctly and develop maximum performance.

## 3.4 TOP PROTECTION PRODUCTS

- **CONTINUO TOP:** transparent two-component water-based acrylurethane aliphatic finishes that do not yellow. After drying, the coatings have a high mechanical resistance to abrasion and scratching as well as good chemical resistance. The CONTINUO TOP finishes are available in the following versions: Satin, Glossy and Matt. Before use, the CONTINUO TOP A finish must be mixed with a new generation CONTINUO TOP B hardener based on an aliphatic polyisocyanate with an HDI monomer content of < 0.1 % by weight, which also allows the simple manual mixing of the 2 components.
- **CONTINUO TOP ART:** transparent two-component water-based acrylurethane aliphatic, non-yellowing finishes with high resistance to cold and hot liquids, and to many substances normally used in the residential and catering sectors. After drying, the CONTINUO TOP ART coatings have a high mechanical resistance to abrasion and scratching, as well as good chemical resistance. The TOP ART finish is available in the Satin version and in a highly 'Matt' version. Before use, the CONTINUO TOP ART finish must be mixed with CONTINUO TOP B, a new-generation reactive resin with a monomer content of HDI < 0.1 % by weight that also allows a simple manual mixing of the 2 components.

Due to their technical characteristics matched with high transparency and their particular natural effect, the **CONTINUO TOP** and **CONTINUO TOP ART** paints can also be used for maintaining already-installed parquet wood.

The **CONTINUO TOP** gloss finish uses the special **CONTINUO TOP gloss comp B** hardener, which optimises the hardening process, guaranteeing fullness, brilliance and final surface performance. **CONTINUO TOP glossy comp B** is based on hydrophilic aliphatic polyisocyanate, which makes it very easy to mix by hand with comp A **CONTINUO TOP glossy**. **CONTINUO TOP glossy comp B** has a content of HDI monomer < 0.1 % by weight HDI (Hexamethylene Diisocyanate), this content being extremely low compared to traditional hardeners, significantly reduces risks for the environment and for those who use and handle the product.

The **CONTINUO TOP** and **CONTINUO TOP ART** finishes in the Satin and Matt versions use the special **CONTINUO TOP comp B** hardener, developed to optimise the appearance and final performance of the surface during the hardening process. **CONTINUO TOP comp B** is based on a special mixture of hydrophilic aliphatic polyisocyanates that makes it extremely easy to mix by hand with all comp A Satin and Mat finishes **CONTINUO TOP** and **CONTINUO TOP ART**. **CONTINUO TOP comp B** has a HDI monomer content of < 0.1 % by weight HDI (Hexamethylene Diisocyanate), which is extremely low compared to traditional hardeners, significantly reduces risks for the environment and for those who use and handle the product.

## 3.5 COMPLEMENTARY PRODUCTS

The **CONTINUO** systems include a wide range of high-quality aesthetic and technical solutions that allow customized solutions to be created that are as close as possible to customers' needs.

To integrate various **CONTINUO** systems when there are particular technical requirements, the manual indicates some products in the general **SAN MARCO** price list.

Where there are horizontal and vertical surfaces covered with non-absorbent ceramic materials, the adhesion primer **PRO LINK** should be used as an adhesion primer for ceramic coatings.

Where there are particularly absorbent or chalky vertical wall surfaces, use **ATOMO**, which is a high-penetration water-dilutable insulating product.



## 4 \_ DECORATIVE EFFECTS

The CONTINUO systems give various solutions for decorating floors, walls, furniture and furnishing accessories. The decorative effects are designed to meet the many technical/aesthetic needs in the private or commercial sectors.

CONTINUO DECO is a decorative spreadable coating that can be colored using the Marcromie tintometric system using the wide range of TOP and TOP ART protection finishes. It is thus possible to create a range of colors and effects of different gloss levels. Surfaces decorated with CONTINUO systems are found in diverse operating contexts. For example, the surface of a kitchen top decorated with a CONTINUO system must withstand temporary contact with hot objects (pots and pans and kitchen utensils), hot-and-cold liquids, and accidental impacts. Depending on the conditions of use, the various CONTINUO systems provide suitable protective solutions.



Before starting to apply the chosen decorative effect, carefully check the dedicated brochures: CONTINUO Cod. 55044, CONTINUO EFFETTO LEGNO (WOOD EFFECT) Cod. 00362, CONTINUO EFFETTO MARMO (MARBLE EFFECT) Cod. 00363, to have a clear idea of the pattern to create and the final result. Only in this way will it be possible to understand the recommendations and application methods below, and obtain optimal results.



The decorative effects CONTINUO EFFETTO LEGNO - COZY - SHABBY CHIC - NORDIC, are unique for creating depth and three-dimensionality to the surface with very low product thickness: less than 3 mm. Especially for horizontal surfaces, we therefore recommend not using excessive thicknesses and to strictly adhere to the amounts given in the technical data sheets

### REQUIRED SKILL LEVEL

The following effects are marked by different REQUIRED SKILL LEVELS. Beside each effect is a scale from 1 to 4 spatulas indicating:

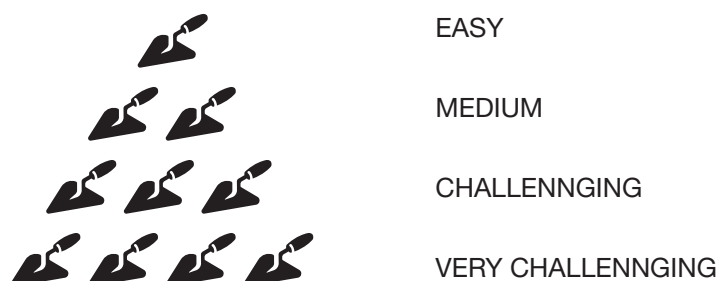

This classification aims to inform applicators on the importance of carefully reading the following indications, starting from the assumption that everyone, even the less expert in the flooring sector, can learn and with little effort by carefully following this manual, the graphic supports, video tutorials on our YouTube channel, and the specialized courses organized in the LAB FOR PRO project. For more information, see the dedicated page at: [www.san-marco.com/ita/formazione-g1-continuo](http://www.san-marco.com/ita/formazione-g1-continuo)

## 4.1 CONTINUO EFFETTO MINIMAL / EFFETTO STYLE

The CONTINUO systems allow you to create 3 types of effects:

- **CONTINUO MINIMAL:** Smooth to the touch, visually flat and 'monolithic', it can be additionally characterized by one of the various degrees of gloss of the CONTINUO TOP or CONTINUO TOP ART finishes.
- **CONTINUO STYLE:** differentiated in the contemporary styles: MONOCROMATICO, with light visual and tactile texture. BICOLORE, smooth with light tone-on-tone color shades.

**MONOCROMATICO:** Created by leaving the first layer of CONTINUO DECO decorative coating slightly uneven by using a steel trowel. The second layer is also applied with CONTINUO DECO but spread over the entire surface with a steel trowel, smoothing the surface very thinly. We then apply the primer CONTINUO LINK ART and one of the TOP ART finishes, as described in section 6\_PREPARATION AND USE OF THE PRODUCTS, AND TECHNICAL CHARACTERISTICS.

**BICOLORE:** This is created by applying (with a steel trowel) the first layer of CONTINUO DECO, a decorative coating in one of the colors of the Continuo colour range (Code 55034), and using a dark color as the base color. The second layer must be lighter in tone and will be applied to the surface using a steel trowel without covering it completely. Two-tone effects can be easily created by adjusting the size of the covered surface and the color contrast between the two CONTINUO DECO colours selected from the CONTINUO pack. Then apply CONTINUO LINK ART primer and one of the TOP ART finishes as described in section 6\_PREPARATION AND USE OF THE PRODUCTS, AND TECHNICAL CHARACTERISTICS.

**Before applying the primer, we recommend sanding lightly with a random orbital sander, using medium-grain sandpaper (120, 150, 180) depending on how smooth you want it to be.**

**The final protection must be carried out using one of the TOP ART finishes following the methods described in section 6\_PREPARATION AND USE OF THE PRODUCTS, AND TECHNICAL CHARACTERISTICS.**

## 4.2 CONTINUO EFFETTO LEGNO (WOOD EFFECT)

- **CONTINUO EFFETTO LEGNO (WOOD EFFECT):** Decorative effects that reinterpret the wood finish and re-propose furnishing styles in a new light. The evolution of COZY, SHABBY CHIC and NORDIC styles according to CONTINUO.



The EFFETTI LEGNO (WOOD EFFECTS) differ in terms of tools to use in making the first layer. COZY = Stainless steel spatula  
SHABBY CHIC = Wood-effect pad  
NORDIC = Doormat trowel



All the effects can be created using combinations of tones of your choice, found in the CONTINUO COLOR RANGE (Code 55034). In the dedicated brochure CONTINUO EFFETTO LEGNO Cod. 00362, some recommended combinations are proposed to obtain results in line with the latest trends.

## COZY EFFECT



This effect is created using paper adhesive tape (we recommend 5 cm wide) to reproduce the classic plank / wooden beam pattern. We recommend making parallel bands at least 15 cm wide. Proceed by applying a layer of CONTINUO DECO in the chosen shade, in alternating bands. Then work the surface by dragging the stainless-steel spatula while the product is still fresh to make irregular streaks and grooves, trying to reproduce the typical wood grain as realistically as possible. Point the QR code here (side) to see this technique.



Remove the paper tape used to outline the bands **while the product is still fresh.**

After drying, repeat the operation on the missing bands.

When fully dry, sand the entire surface lightly with a low-speed orbital sanding machine (grain 80 - 120).

Finish the surface in sections, applying a low-thickness layer of CONTINUO DECO in the chosen shade different from the one used for the first layer, filling the previously-made streaks and grooves. Point the QR code here (side) to see this technique. Before fully dry, scrape the surface with a stainless-steel spatula.

When completely dry, sand with orbital sanding (grain size 80 - 120) to highlight the veins and underlying pattern. Then apply a layer of CONTINUO LINK using a roller. Finish by applying (by roller) 2 coats of CONTINUO TOP ART in the desired finish respecting the drying times given in chapter 6\_PREPARATION, USE OF PRODUCTS AND TECHNICAL FEATURES.

## SHABBY CHIC EFFECT



This effect is created using paper adhesive tape (we recommend 5 cm wide) to reproduce the classic plank / wooden beam pattern. We recommend making parallel bands at least 15 cm wide. Apply a layer of CONTINUO DECO in the chosen shade in alternating bands. While the product is still fresh, use a wood-effect pad, necessarily with a wide weft to make the typical wood grain visible and well-finished. Point the QR code here (side) to see this technique.



Remove the paper tape used to outline the bands while the product is still fresh. After drying, repeat the operation on the missing strips. When fully dry, sand the entire surface lightly with a low-speed orbital sanding machine (grain 80 - 120).

Finish the surface in sections, applying a thin layer of CONTINUO DECO BIANCO (white), filling in the previously-made streaks and grooves. Point the QR code here (side) to see this technique.

Then apply a layer of CONTINUO LINK using a roller.

Finish by applying (by roller) 2 coats of CONTINUO TOP ART in the desired finish respecting the drying times given in chapter 6\_PREPARATION, USE OF PRODUCTS AND TECHNICAL FEATURES.



## NORDIC EFFECT



This effect is created using paper adhesive tape (we recommend 5 cm wide) to reproduce the classic plank / wooden beam pattern. We recommend making parallel bands at least 15 cm wide.

Apply a coat of CONTINUO DECO in the chosen shade in alternating bands with a steel trowel, and pass the doormat trowel while the product is still fresh to achieve the grain effect of planed wood. Point the QR code here (side) to see this technique



Remove the paper tape used to outline the bands **while the product is still fresh.**

After drying, repeat the operation on the missing strips.

Finish the surface in sections, applying a low-thickness layer of CONTINUO DECO in the chosen shade different from the one used for the first layer, filling the previously-made streaks and grooves. Point the QR code here (side) to see this technique.

When fully dry, sand the entire surface lightly with a low-speed orbital sanding machine (grain 80 - 120). Vacuum the surface and clean it thoroughly.

Then apply a layer of CONTINUO LINK using a roller. Finish by applying (by roller) 2 coats of CONTINUO TOP ART in the desired finish respecting the drying times given in chapter 6\_ PREPARATION, USE OF PRODUCTS AND TECHNICAL FEATURES.

## 4.3 CONTINUO EFFETTO MARMO (MARBLE-EFFECT)

- **CONTINUO EFFETTO MARMO (MARBLE-EFFECT):** Decorative effects that reinterpret marble and propose furnishing styles in a new light. The evolution of LUXURY, MODERN and CLASSIC CHIC styles according to CONTINUO.



All the effects can be created using combinations of tones of your choice, found in the CONTINUO COLOR RANGE (Cod. 55034). In the dedicated brochure CONTINUO EFFETTO LEGNO Cod. 00363, some recommended combinations are proposed to obtain results in line with the latest trends.

### EFFETTO LUXURY (LUXURY EFFECT)



This is created by applying a layer of CONTINUO DECO in the chosen shade over the entire surface using a steel trowel.

After drying, apply a second layer of CONTINUO DECO with a stainless steel trowel in the same shade, distributing the product evenly, and taking care to leave empty spaces and grooves, which will represent the veins and surface design when the cycle is complete. Point the QR code here (side) to see this technique.



When the product is **still wet**, fill with CONTINUO DECO BIANCO (white), levelling and fading the surface.

With the tip of the spatula, you can refine and accentuate the veins depending on whether you want a more nuanced effect between the bands, or a more defined one. Point the QR code here (side) to see this technique.

When fully dry, sand the entire surface with a roto-orbital sander (grain size 80 - 120). Vacuum the surface and clean it thoroughly. Then apply a layer of CONTINUO LINK using a roller.

Finish by applying (by roller) 2 coats of CONTINUO TOP ART in the desired finish respecting the drying times given in chapter 6\_PREPARATION, USE OF PRODUCTS AND TECHNICAL FEATURES.

### EFFETTO MODERN (MODERN EFFECT)



This is created by applying a layer of CONTINUO DECO BIANCO on the entire surface using a steel trowel.



When dry, apply a second layer of CONTINUO DECO BIANCO with a stainless steel trowel with alternating uneven bands, leaving large empty areas between one band and the other. Point the QR code here (side) to see this technique.

While the product is still wet, fill the areas and empty spaces with CONTINUO DECO in the chosen shade, levelling the surface to obtain the characteristic marble effects. With the tip of the spatula, you can refine and accentuate the veins depending on whether you want a more nuanced effect between the bands, or a more defined one. Point the QR code here (side) to see this technique.

When dry, sand the entire surface with a roto-orbital sander (grain size 80 - 120). Vacuum the surface and clean it thoroughly.

Then apply a layer of CONTINUO LINK using a roller. Finish by applying (by roller) 2 coats of CONTINUO TOP ART in the desired finish respecting the drying times given in chapter 6\_PREPARATION, USE OF PRODUCTS AND TECHNICAL FEATURES.

### EFFETTO CLASSIC CHIC (CLASSIC CHIC EFFECT)



This is created by applying a layer of CONTINUO DECO in the chosen shade, over the entire surface using a steel trowel.

After drying, apply CONTINUO DECO BIANCO using a stainless steel trowel, proceeding in portions of about 50 x 50 cm; then, using the tip of the trowel, create irregular grooves that will represent the typical veins of marble. Point the QR code here (side) to see this technique.

When dry, sand the entire surface with a roto-orbital sander (grain size 80 - 120). Vacuum the surface and clean it thoroughly.

Then apply a layer of CONTINUO LINK using a roller. Finish by applying (by roller) 2 coats of CONTINUO TOP ART in the desired finish respecting the drying times given in chapter 6\_PREPARATION, USE OF PRODUCTS AND TECHNICAL FEATURES.



## 4.4 CONTINUO OXIDIZED EFFECTS

The oxidation effect of metals, with an industrial and vaguely retro charm, has been one of the main trends in interior design and decoration for many years.

The new visual effects of CONTINUO also involve Roxidan, a decorative oxidised-effect finish, to recreate modern or vintage atmospheres, emphasise lines and spaces, on walls and floors, exposed stairs, in niches and other spatial features.

The proposed OXIDATION EFFECTS are created through specific application techniques of Continuo Deco, combined with the applications of Link-art mixed with Roxidan in different shades.



The mixing ratio between Link-Art and Roxidan must respect the following proportions:

1 part Component A + 0.7 parts Component B + 2 parts ROXIDAN + 2 parts WATER

500 g A + 350 g B + 1,000 g ROXIDAN + 1,000 g WATER

**Mixture preparation:** thoroughly mix in CONTINUO LINK ART component A to create a smooth, homogenous paste.

Pour CONTINUO LINK ART component B into CONTINUO LINK ART component A and mix together manually for approximately 45-60 seconds.

Add 1,000 g of Roxidan to the mixture of LINK\_ART A+B (0.500 g of component A + 0.350 g of component B) previously obtained; then mix manually for about 45-60 seconds until a uniform consistency is obtained.

**Dilution:** dilute the mixture obtained (0.500 g of component A + 0.350 g of component B + 1,000 g Roxidan) by adding 1,000 g of water.

**Mixture life:** approximately 60 minutes.

**It must not be used beyond this time as although the product may still be malleable, using it may affect the final performance of the system.**

All the effects can be created using combinations of tones of your choice, found in the CONTINUO colour swatch (Code 55034). In the **(DEDICATED BOX Code ???)** some suggested combinations are proposed to obtain results in keeping with the latest trends.

For surfaces where you want maximum resistance to liquids, a layer of Link\_art Trasparente should be spread over the mixture of Link\_art and Roxidan, depending on the procedures given in the technical data sheet.





## BROWN RUST EFFECT



Creation of the texture: CONTINUO DECO colour C643.

Apply a layer of Continuo Deco evenly with a steel trowel, laying a thickness that achieves the effect, slightly rippling some areas by dabbing with the trowel's flat surface. When the surface is dry, apply a second coat of product again with a steel trowel, covering the first coat completely. Whilst the product is drying, use a steel trowel to compact it until you obtain the desired finish.

When dry, sand the entire surface with a roto-orbital sander (grain size 80 - 120). Vacuum clean the surface and clean it thoroughly.

Finishing product: mixture of CONTINUO LINK\_ART + ROXIDAN PERLA

When the layers of Deco are completely dry, apply one layer of the mixture evenly with a medium-pile roller, crossing the rolls to blend.

Finish by applying (by roller) 2 coats of CONTINUO TOP ART in the desired finish respecting the drying times given in chapter 6\_PREPARATION, USE OF PRODUCTS AND TECHNICAL FEATURES.



## RUST METAL EFFECT



Creation of the texture: CONTINUO DECO colour C636.

Apply a coat of Continuo Deco uniformly with a steel trowel, laying a thickness suitable for achieving the effect. When the surface is dry, apply a second coat of product again with a steel trowel, covering the first coat completely. Whilst the product is drying, use a steel trowel to compact it until you obtain the desired finish.

When dry, sand the entire surface with a roto-orbital sander (grain size 80 - 120). Vacuum clean the surface and clean it thoroughly.

Finishing product: mixture of CONTINUO LINK\_ART + ROXIDAN colour 0270 and mixture LINK\_ART + ROXIDAN PLATINO

When the layers of Deco are completely dry, use a short-pile roller to apply the decorative mixtures in parallel bands, alternating the two colours wet-on-wet, blending until the desired texture is obtained.

Finish by applying (by roller) 2 coats of CONTINUO TOP ART in the desired finish respecting the drying times given in chapter 6\_PREPARATION, USE OF PRODUCTS AND TECHNICAL FEATURES.



## INDUSTRIAL EFFECT



Creation of the texture: CONTINUO DECO colour C620.

Apply a coat of Continuo Deco uniformly with a steel trowel, laying a thickness suitable for achieving the effect. When the surface is dry, apply a second coat of product again with a steel trowel, covering the first coat completely. Whilst the product is drying, use a steel trowel to compact it until you obtain the desired finish.

When dry, sand the entire surface with a roto-orbital sander (grain size 80 - 120). Vacuum clean the surface and clean it thoroughly.

Finishing product: mixture CONTINUO LINK\_ART + ROXIDAN PLATINO and mixture LINK\_ART + ROXIDAN colour 0272

When the layers of Deco are completely dry, apply the two decorative mixtures, alternating the colours wet-on-wet, blending with the sponge and doormat until you obtain the desired texture.

Finish by applying (by roller) 2 coats of CONTINUO TOP ART in the desired finish respecting the drying times given in chapter 6\_PREPARATION, USE OF PRODUCTS AND TECHNICAL FEATURES.



## SMOKEY STEEL EFFECT



Creation of the texture : CONTINUO DECO colour C615.

Apply a layer of Continuo Deco with a steel trowel, with irregular thickness (maximum 1 mm) in order to create an uneven texture. When the surface is dry, apply a second coat of product again with a steel trowel, covering the first coat completely. Whilst the product is drying, use a steel trowel to compact it until you obtain the desired finish.

When dry, sand the entire surface with a roto-orbital sander (grain size 80 - 120). Vacuum clean the surface and clean it thoroughly.

Finishing product: mixture CONTINUO LINK\_ART + ROXIDAN PLATINO and mixture LINK\_ART + ROXIDAN colour 0272.

When the layers of Deco are completely dry, apply the mixture containing Roxidan Platino, blending with sponge and steel trowel until you obtain the desired texture.

Apply the mixture containing Roxidan 0272, blending with a sponge and steel trowel until the desired texture is obtained. If necessary, repeat the operation several times.

Finish by applying (by roller) 2 coats of CONTINUO TOP ART in the desired finish respecting the drying times given in chapter 6\_PREPARATION, USE OF PRODUCTS AND TECHNICAL FEATURES..



## MOTTLED EFFECT



Creation of the texture : CONTINUO DECO colour C626.

Apply a layer of Continuo Deco with a steel trowel, with irregular thickness (maximum 1 mm) in order to create an uneven texture. When the surface is dry, apply a second coat of product again with a steel trowel, covering the first coat completely. When the product is drying, use a steel trowel to compact it until you obtain the desired finish.

When dry, sand the entire surface with a roto-orbital sander (grain size 80 - 120). Vacuum clean the surface and clean it thoroughly.

Finishing product: mixture of CONTINUO LINK\_ART + ROXIDAN PLATINO and mixture of LINK\_ART + ROXIDAN colour 0270.

When the layers of Deco are completely dry, apply the mixture containing Roxidan Platino, blending with sponge and steel trowel until you obtain the desired texture.

Apply the mixture containing Roxidan 0270, blending with a sponge and steel trowel until the desired texture is obtained. If necessary, repeat the operation several times.

Finish by applying (by roller) 2 coats of CONTINUO TOP ART in the desired finish respecting the drying times given in chapter 6\_PREPARATION, USE OF PRODUCTS AND TECHNICAL FEATURES.



**Gloss level of the CONTINUO systems surface:**

20 ± 2	reading angle of 60°	<b>TOP GLOSSY</b>
6 ± 1	reading angle of 60°	<b>TOP SATIN</b>
3 ± 1	reading angle of 85°	<b>TOP MATT</b>
6 ± 1	reading angle of 60°	<b>TOP ART SATIN</b>
1 ± 1	reading angle of 85°	<b>TOP ART MATT</b>

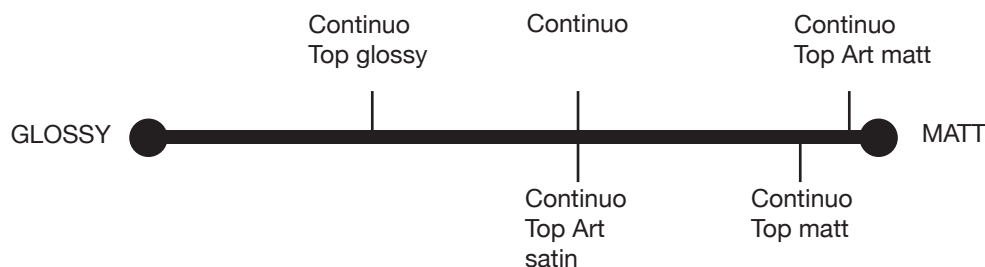

## 5\_SYSTEMS APPLICATION

The **CONTINUO** products have been studied to be used in a modular way. The application of the CONTINUO system most suited to the style and performance required (LIVING, ACTIVITY, STUDIO, LOUNGE, PATIO, FORNITURE) will be consistent and long-lasting by simply respecting the instructions in the step-by-step operating phases of this manual.

For the final protection of the **CONTINUO** systems, depending on the decoration, it is essential to comply with the technical recommendations:

- **CONTINUO MINIMAL**, smooth to the touch, visually flat and monolithic; protection can only be achieved with the CONTINUO LINK primer and one of the CONTINUO TOP or TOP ART finishes.
- **CONTINUO STYLE**, in the monochrome, two-tone, creative natural or semi-covering effects, protection can only be achieved with the CONTINUO LINK ART primer and one of the CONTINUO TOP ART finishes.
- **CONTINUO EFFETTO LEGNO**, in the COZY, SHABBY CHIC and NORDIC effects, the protection can only be achieved with CONTINUO LINK and one of the CONTINUO TOP ART finishes.
- **CONTINUO EFFETTO MARMO**, in the LUXURY, MODERN and CLASSIC CHIC effects, the protection can only be achieved with CONTINUO LINK and one of the CONTINUO TOP ART finishes.



**Surfaces decorated and protected with the transparent finish will be walkable and can withstand light traffic after 24 hours from application of the last layer.**

**Full chemical-physical resistance will be reached after about 5 days. During this period, to avoid possible aesthetic alterations to the surface, do not cover it with sheets or cardboard.**



## 5.1 AREAS AND ENVIRONMENTS



The **CONTINUO LIVING** system is for the needs regarding surfaces in typically residential and environments such as kitchens, living rooms etc. It is not intended for bathrooms, laundries and garages.

### The CONTINUO LIVING System



**Vertical surfaces:**  
absorbent substrates, new and old plasters based on hydraulic binders, concrete surfaces inside, plasterboard surfaces.

Stage	Product	Coat	When?	Tools/equipment
0	ATOMO	one	work begins	brush
1	CONTINUO DECO	one of three	after 3 hrs from stage 0	steel trowel
2	CONTINUO DECO	two of three	after 3 hrs from stage 1	steel trowel
3	CONTINUO DECO *	three of three	after at least 3 hrs from stage 2	steel trowel
4	CONTINUO LINK or LINK ART	one of one	after at least 12 hrs from stage 3	roller
5	CONTINUO TOP or TOP ART	one of two	after at least 4 hrs from stage 4	roller
6	CONTINUO TOP or TOP ART	two of two	after at least 3 hrs from stage 5	roller

\* on particularly smooth and regular surfaces, it is possible to apply only two layers of CONTINUO DECO.



**CONTINUO LIVING System**  
Surfaces tiled with ceramic, porcelain, mosaic.

Stage	Product	Coat	When?	Tools/equipment
0	Pro-Link	one	work begins	brush-roller
1	CONTINUO BASE	one of one	after 3 hrs from stage 0	steel trowel
2	CONTINUO DECO	one of two	after at least 3 hrs from stage 1	steel trowel
3	CONTINUO DECO	two of two	after at least 3 hrs from stage 2	steel trowel
4	CONTINUO LINK or LINK ART	one of one	after at least 12 hrs from stage 3	roller
5	CONTINUO TOP or TOP ART	one of two	after at least 4 hrs from stage 4	roller
6	CONTINUO TOP or TOP ART	two of two	after at least 3 hrs from stage 5	roller



**CONTINUO LIVING System**  
**Horizontal surfaces thickness possible <3 mm screeds.**

Stage	Product	Coat	When?	Tools/equipment
1	CONTINUO BASE + MESH	one of two	work begins	steel trowel
2	CONTINUO BASE	two of two	after 3 hrs from stage 1	steel trowel
3	CONTINUO DECO	one of two	after at least 3 hrs from stage 2	steel trowel
4	CONTINUO DECO	two of two	after at least 3 hrs from stage 3	steel trowel
5	CONTINUO LINK or LINK ART	one of one	after at least 12 hrs from stage 4	roller
6	CONTINUO TOP or TOP ART	one of two	after at least 4 hrs from stage 5	roller
7	CONTINUO TOP or TOP ART	two of two	after at least 3hrs from stage 6	roller



**CONTINUO LIVING System**  
**Horizontal surfaces thickness possible <3 mm ceramic tiles, porcelain stoneware, single-fired ware, mosaic, stones, similar.**

Stage	Product	Coat	When?	Tools/equipment
0	Pro-Link	one	work begins	brush- roller
1	CONTINUO BASE + MESH	one of two	after 3 hrs from stage 0	steel trowel
2	CONTINUO BASE	two of two	after 3 hrs from stage 1	steel trowel
3	CONTINUO DECO	one of two	after at least 3 hrs from stage 2	steel trowel
4	CONTINUO DECO	two of two	after at least 3 hrs from stage 3	steel trowel
5	CONTINUO LINK or LINK ART	one of one	after at least 12 hrs from stage 4	roller
6	CONTINUO TOP	one of two	after at least 4 hrs from stage 5	roller
7	CONTINUO TOP	two of two	after at least 3 hrs from stage 6	roller



**CONTINUO LIVING System**  
**Horizontal surfaces thickness possible >3 mm screeds.**

Stage	Product	Coat	When?	Tools/equipment
1	CONTINUO LEVEL_ZERO	one	work begins	trowel- bubble breaker roller
2	CONTINUO DECO	one of two	after at least 24 hrs from stage 1	steel trowel
3	CONTINUO DECO	two of two	after at least 3 hrs from stage 2	steel trowel
4	CONTINUO LINK or LINK ART	one of one	after at least 12 hrs from stage 3	roller
5	CONTINUO TOP	one of two	after at least 4 hrs from stage 4	roller
6	CONTINUO TOP	two of two	after at least 3 hrs from stage 5	roller



### CONTINUO LIVING System

Horizontal surfaces thickness possible >3 mm.  
ceramic tiles, porcelain stoneware, single-fired ware, mosaic, stones, similar.

Stage	Product	Coat	When?	Tools/equipment
0	Pro-Link	one	work begins	brush- roller
1	CONTINUO LEVEL_ZERO	one	after 3 hrs from stage 0	trowel- bubble breaker roller
2	CONTINUO DECO	one of two	after at least 24 hrs from stage 1	steel trowel
3	CONTINUO DECO	two of two	after at least 3 hrs from stage 2	steel trowel
4	CONTINUO LINK or LINK ART	one of one	after at least 12 hrs from stage 3	roller
5	CONTINUO TOP	one of two	after at least 4 hrs from stage 4	roller
6	CONTINUO TOP	two of two	after at least 3 hrs from stage 5	roller



The **CONTINUO ACTIVITY** system is intended for the needs of residential surfaces and environments where a good resistance against water, wear-and-tear and stains from food, drink and household substances, is required. Suitable for use in bathrooms, laundries and kitchens.



### CONTINUO ACTIVITY System

Vertical surfaces absorbent substrates, new and old plasters based on hydraulic binders, concrete surfaces inside, plasterboard surfaces.

Stage	Product	Coat	When?	Tools/equipment
0	ATOMO	one	work begins	brush
1	CONTINUO DECO	one of three	after 3 hrs from stage 0	steel trowel
2	CONTINUO DECO	two of three	after 3 hrs from stage 1	steel trowel
3	CONTINUO DECO*	three of three	after at least 3 hrs from stage 2	steel trowel
4	CONTINUO LINK or LINK ART	one of one	after at least 12 hrs from stage 3	roller
5	CONTINUO TOP or TOP ART	one of two	after at least 4 hrs from stage 4	roller
6	CONTINUO TOP or TOP ART	two of two	after at least 3 hrs from stage 5	roller

\* On particularly smooth and regular surfaces, it is possible to apply only two layers of CONTINUO DECO.





### CONTINUO ACTIVITY System

#### Vertical surfaces

ceramic tiles, porcelain stoneware, single-fired ware, mosaic, stones, similar.

Stage	Product	Coat	When?	Tools/equipment
0	Pro-Link	one	work begins	brush -roller
1	CONTINUO BASE	one of one	after 3 hrs from stage 0	steel trowel
2	CONTINUO DECO	one of two	after at least 3 hrs from stage 1	steel trowel
3	CONTINUO DECO	two of two	after at least 3 hrs from stage 2	steel trowel
4	CONTINUO LINK or LINK ART	one of one	after at least 12 hrs from stage 3	roller
5	CONTINUO TOP or TOP ART	one of two	after at least 4 hrs from stage 4	roller
6	CONTINUO TOP or TOP ART	two of two	after at least 3 hrs from stage 5	roller



### CONTINUO ACTIVITY System

Horizontal surfaces thickness possible >3 mm screeds.

Stage	Product	Coat	When?	Tools/equipment
1	CONTINUO BASE + MESH	one of two	work begins	steel trowel
2	CONTINUO BASE	two of two	after 3 hrs from stage 1	steel trowel
3	CONTINUO DECO	one of two	after at least 3 hrs from stage 2	steel trowel
4	CONTINUO DECO	two of two	after at least 3 hrs from stage 3	steel trowel
5	CONTINUO LINK or LINK ART	one of one	after at least 12 hrs from stage 4	roller
6	CONTINUO TOP ART	one of two	after at least 4 hrs from stage 5	roller
7	CONTINUO TOP ART	two of two	after at least 3 hrs from stage 6	roller



### CONTINUO ACTIVITY System

Horizontal surfaces thickness possible <3 mm

ceramic tiles, porcelain stoneware, single-fired ware, mosaic, stones, similar.

Stage	Product	Coat	When?	Tools/equipment
0	Pro-Link	one	work begins	brush-roller
1	CONTINUO BASE + MESH	one of two	after 3 hrs from stage 0	steel trowel
2	CONTINUO BASE	two of two	after 3 hrs from stage 1	steel trowel
3	CONTINUO DECO	one of two	after at least 3 hrs from stage 2	steel trowel
4	CONTINUO DECO	two of two	after at least 3 hrs from stage 3	steel trowel
5	CONTINUO LINK or LINK ART	one of one	after at least 12 hrs from stage 4	roller
6	CONTINUO TOP ART	one of two	after at least 4 hrs from stage 5	roller
7	CONTINUO TOP ART	two of two	after at least 3 hrs from stage 6	roller



**CONTINUO ACTIVITY System**  
Horizontal surfaces thickness possible >3 mm  
screeds.

Stage	Product	Coat	When?	Tools/equipment
1	CONTINUO LEVEL_ZERO	one	work begins	trowel- bubble breaker roller
2	CONTINUO DECO	one of two	after at least 24 hrs from stage 1	steel trowel
3	CONTINUO DECO	two of two	after at least 3 hrs from stage 2	steel trowel
4	CONTINUO LINK or LINK ART	one of one	after at least 12 hrs from stage 3	roller
5	CONTINUO TOP ART	one of two	after at least 4 hrs from stage 4	roller
6	CONTINUO TOP ART	two of two	after at least 3 hrs from stage 5	roller



**CONTINUO ACTIVITY System**  
Horizontal surfaces thickness possible >3 mm  
ceramic tiles, porcelain stoneware, single-fired ware, mosaic, stones, similar.

Stage	Product	Coat	When?	Tools/equipment
0	Pro-Link	one	work begins	brush-roller
1	CONTINUO LEVEL_ZERO	one	after 3 hrs from stage 0	trowel- bubble breaker roller
2	CONTINUO DECO	one of two	after at least 12 hrs 1	steel trowel
3	CONTINUO DECO	two of two	after at least 3 hrs from stage 2	steel trowel
4	CONTINUO LINK or LINK ART	one of one	after at least 12 hrs from stage 3	roller
5	CONTINUO TOP ART	one of two	after at least 6 hrs from stage 4	roller
6	CONTINUO TOP ART	two of two	after at least 3 hrs from stage 5	roller



The **CONTINUO STUDIO** system is dedicated to the needs of residential surfaces and contexts, or for studios and offices. Recommended for places that require a medium resistance to pedestrian traffic.



The **CONTINUO LOUNGE** System is intended to meet the needs of commercial areas and contexts used for public establishments with medium traffic intensity such as bars, restaurants, beauty areas, accommodation facilities, specialized private services (clinics, schools and training centres), and offices with medium foot-traffic and/or wheelchair passage. This system is specific for where finishes are required with ease of cleaning and good resistance to water, food/drink stains and substances commonly used in catering. It is not for where there are strongly acidic or alkaline substances.

The **CONTINUO LOUNGE** solution does not include areas subject to other traffic (factories, workshops, warehouses, wholesale facilities, supermarkets etc).



### CONTINUO STUDY - LOUNGE

#### Vertical surfaces

**Absorbent substrates, new and old plasters based on hydraulic binders, concrete surfaces inside, plasterboard surfaces.**

Stage	Product	Coat	When?	Tools/equipment
0	ATOMO	one	work begins	brush
1	CONTINUO DECO	one of three	after 3 hrs from stage 0	steel trowel
2	CONTINUO DECO	two of three	after 3 hrs from stage 1	steel trowel
3	CONTINUO DECO *	three of three	after 3 hrs from stage 2	steel trowel
4	CONTINUO LINK or LINK ART	one of one	after at least 12 hrs from stage 3	roller
5	CONTINUO TOP or TOP ART	one of two	after at least 4 hrs from stage 4	roller
6	CONTINUO TOP or TOP ART	two of two	after at least 3 hrs from stage 5	roller

\* On particularly smooth and regular surfaces, it is possible to apply only two layers of CONTINUO DECO.



### STUDIO - LOUNGE System

#### Vertical surfaces

**ceramic tiles, porcelain stoneware, single-fired ware, mosaic, stones, similar.**

Stage	Product	Coat	When?	Tools/equipment
0	Pro-Link	one	work begins	brush-roller
1	CONTINUO BASE	one of one	after 3 hrs from stage 0	steel trowel
2	CONTINUO DECO	one of two	after at least 3 hrs from stage 1	steel trowel
3	CONTINUO DECO	two of two	after at least 3 hrs from stage 2	steel trowel
4	CONTINUO LINK or LINK ART	one of one	after at least 12 hrs from stage 3	roller
5	CONTINUO TOP or TOP ART	one of two	after at least 4 hrs from stage 4	roller
6	CONTINUO TOP or TOP ART	two of two	after at least 3 hrs from stage 5	roller



### CONTINUO STUDIO - LOUNGE Systems

**Horizontal surfaces thickness possible <3 mm screeds.**

Stage	Product	Coat	When?	Tools/equipment
1	EPOXY COMBO + CONTINUO BASE + MESH	one of two	work begins	steel trowel
2	EPOXY COMBO + CONTINUO BASE	two of two	after 4 hrs from stage 1	steel trowel
3	CONTINUO DECO	one of two	after at least 6 hrs from stage 2	steel trowel
4	CONTINUO DECO	two of two	after at least 3 hrs from stage 3	steel trowel
5	CONTINUO LINK or LINK ART	one of one	after at least 12 hrs from stage 4	roller
6	CONTINUO TOP ART	one of two	after at least 4 hrs from stage 5	roller
7	CONTINUO TOP ART	two of two	after at least 3 hrs from stage 6	roller



**CONTINUO STUDIO - LOUNGE Systems**  
Horizontal surfaces thickness possible <3 mm  
ceramic tiles, porcelain stoneware, single-fired ware, mosaic, stones,  
similar.

Stage	Product	Coat	When?	Tools/equipment
0	Pro-Link	one	work begins	brush-roller
1	EPOXY COMBO + CONTINUO BASE + MESH	one of two	after 3 hrs from stage 0	steel trowel
2	EPOXY COMBO + CONTINUO BASE	two of two	after 4 hrs from stage 1	steel trowel
3	CONTINUO DECO	one of two	after at least 6 hrs from stage 2	steel trowel
4	CONTINUO DECO	two of two	after at least 3 hrs from stage 3	steel trowel
5	CONTINUO LINK or LINK ART	one of one	after at least 12 hrs from stage 4	roller
6	CONTINUO TOP ART	one of two	after at least 4 hrs from stage 5	roller
7	CONTINUO TOP ART	two of two	after at least 3 hrs from stage 6	roller



**CONTINUO STUDIO- LOUNGE Systems**  
Horizontal surfaces thickness possible >3 mm  
screeds.

Stage	Product	Coat	When?	Tools/equipment
1	LEVEL_ZERO	one of two	work begins	trowel- bubble breaker roller
2	EPOXY COMBO + CONTINUO BASE	two of two	after 24 hrs from stage 1	steel trowel
3	CONTINUO DECO	one of two	after at least 6 hrs from stage 2	steel trowel
4	CONTINUO DECO	two of two	after at least 3 hrs from stage 3	steel trowel
5	CONTINUO LINK or LINK ART	one of one	after at least 12 hrs from stage 4	roller
6	CONTINUO TOP ART	one of two	after at least 4 hrs from stage 5	roller
7	CONTINUO TOP ART	two of two	after at least 3 hrs from stage 6	roller



**CONTINUO STUDIO- LOUNGE Systems**  
Horizontal surfaces thickness possible >3 mm  
ceramic tiles, porcelain stoneware, single-fired ware, mosaic, stones,  
similar.

Stage	Product	Coat	When?	Tools/equipment
0	Pro-Link	one	work begins	brush-roller
1	LEVEL_ZERO	one of two	after 3 hrs from stage 0	trowel- bubble breaker roller
2	EPOXY COMBO + CONTINUO BASE	two of two	after 24 hrs from stage 1	steel trowel
3	CONTINUO DECO	one of two	after at least 6 hrs from stage 2	steel trowel
4	CONTINUO DECO	two of two	after at least 3 hrs from stage 3	steel trowel
5	CONTINUO LINK or LINK ART	one of one	after at least 12 hrs from stage 4	roller
6	CONTINUO TOP ART	one of two	after at least 4 hrs from stage 5	roller
7	CONTINUO TOP ART	two of two	after at least 3 hrs from stage 6	roller





The **CONTINUO PATIO** system is intended for protected exterior surfaces of residential contexts. Surfaces partly exposed to weathering such as patios/terraces and areas around homes. Not included are areas around swimming pools and car-parking areas.



### CONTINUO PATIO System

#### Vertical surfaces

absorbent substrates, new and old plasters based on hydraulic binders, concrete surfaces, plasterboard.

Stage	Product	Coat	When?	Tools/equipment
0	ATOMO	one	work begins	brush
1	CONTINUO DECO	one of three	after 3 hrs from stage 0	steel trowel
2	CONTINUO DECO	two of three	after 3 hrs from stage 1	steel trowel
3	CONTINUO DECO*	three of three	after at least 3 hrs from stage 2	steel trowel
4	CONTINUO LINK or LINK ART	one of one	after at least 12 hrs from stage 3	roller
5	CONTINUO TOP or TOP ART	one of two	after at least 4 hrs from stage 4	roller
6	CONTINUO TOP or TOP ART	two of two	after at least 3 hrs from stage 5	roller

\* On particularly smooth and regular surfaces, it is possible to apply only two layers of CONTINUO DECO.



### CONTINUO PATIO System

#### Vertical surfaces

ceramic tiles, porcelain stoneware, mosaics.

Stage	Product	Coat	When?	Tools/equipment
0	Pro-Link	one	work begins	brush-roller
1	CONTINUO BASE	one of one	after 3 hrs from stage 0	steel trowel
2	CONTINUO DECO	one of two	after at least 3 hrs from stage 1	steel trowel
3	CONTINUO DECO	two of two	after at least 3 hrs from stage 2	steel trowel
4	CONTINUO LINK or LINK ART	one of one	after at least 12 hrs from stage 3	roller
5	CONTINUO TOP or TOP ART	one of two	after at least 4 hrs from stage 4	roller
6	CONTINUO TOP or TOP ART	two of two	after at least 3 hrs from stage 5	roller



**CONTINUO PATIO System**  
Horizontal surfaces thickness possible <3 mm  
screeds or concrete.

Stage	Product	Coat	When?	Tools/equipment
1	EPOXY COMBO + CONTINUO BASE + MESH	one of two	work begins	steel trowel
2	EPOXY COMBO + CONTINUO BASE	two of two	after 6 hrs from stage 1	steel trowel
3	CONTINUO DECO	one of two	after at least 6 hrs from stage 2	steel trowel
4	CONTINUO DECO	two of two	after at least 3 hrs from stage 3	steel trowel
5	CONTINUO LINK	one of one	after at least 12 hrs from stage 4	roller
6	CONTINUO TOP	one of two	after at least 4 hrs from stage 5	roller
7	CONTINUO TOP	two of two	after at least 3 hrs from stage 6	roller



**CONTINUO PATIO System**  
Horizontal surfaces thickness possible <3 mm  
ceramic tiles, porcelain stoneware, single-fired ware, mosaic, stones, similar.

Stage	Product	Coat	When?	Tools/equipment
0	Pro-Link	one	work begins	brush-roller
1	EPOXY COMBO + CONTINUO BASE + MESH	one of two	after 3 hrs from stage 0	trowel - roller
2	EPOXY COMBO + CONTINUO BASE	two of two	after 4 hrs from stage 1	steel trowel
3	CONTINUO DECO	one of two	after at least 6 hrs from stage 2	steel trowel
4	CONTINUO DECO	two of two	after at least 3 hrs from stage 3	steel trowel
5	CONTINUO LINK	one of one	after at least 12 hrs from stage 4	roller
6	CONTINUO TOP	one of two	after at least 6 hrs from stage 5	roller
7	CONTINUO TOP	two of two	after at least 3 hrs from stage 6	roller



The **CONTINUO FURNITURE** system is for customizing furniture, complements and other items in private or commercial settings. Non included are surfaces used for intensive professional purposes (kitchens and restaurants). Before decorating with the CONTINUO system, furniture and surfaces subject to mechanical stress (e.g. shelves or tables) must be properly evaluated and/or sized according to the possible stresses from use.

Every CONTINUO system has a technical Annex containing the technical specifications on area of use. For further information or to request a copy of the test reports, please contact our technical service.

The CONTINUO systems are not suitable for surfaces made of plastic material, plastic conglomerates or similar.



### CONTINUO FURNITURE System

**Horizontal surfaces not walked on thickness possible <3 mm mineral absorbent backgrounds, reinforced concrete slab and similar, MDF of suitable thickness.**

Stage	Product	Coat	When?	Tools/equipment
1	EPOXY COMBO + CONTINUO BASE + MESH	one of two	work begins	steel trowel
2	EPOXY COMBO + CONTINUO BASE	two of two	after 6 hrs from stage 1	steel trowel
3	CONTINUO DECO	one of two	after at least 6 hrs from stage 2	steel trowel
4	CONTINUO DECO	two of two	after at least 3 hrs from stage 3	steel trowel
5	CONTINUO LINK or LINK ART	one of one	after at least 12 hrs from stage 4	roller
6	CONTINUO TOP ART	one of two	after at least 4 hrs from stage 5	roller
7	CONTINUO TOP ART	two of two	after at least 3 hrs from stage 6	roller



### CONTINUO FURNITURE System

**Horizontal surfaces not walked on thickness possible <3 mm ceramic tiles, mosaic, stones, similar.**

Stage	Product	Coat	When?	Tools/equipment
0	Pro-Link	one	work begins	brush-roller
1	EPOXY COMBO + CONTINUO BASE + MESH	one of two	after 3 hrs from stage 0	trowel - roller
2	EPOXY COMBO + CONTINUO BASE	two of two	after 4 hrs from stage 1	steel trowel
3	CONTINUO DECO	one of two	after at least 6 hrs from stage 2	steel trowel
4	CONTINUO DECO	two of two	after at least 3 hrs from stage 3	steel trowel
5	CONTINUO LINK or LINK ART	one of one	after at least 12 hrs from stage 4	roller
6	CONTINUO TOP ART	one of two	after at least 6 hrs from stage 5	roller
7	CONTINUO TOP ART	two of two	after at least 3 hrs from stage 6	roller

## 6 PREPARATION AND USE OF THE PRODUCTS, AND TECHNICAL CHARACTERISTICS

The application of the CONTINUO system will be easy and the surfaces decorated will be even and long-lasting, simply by respecting the information in the step-by-step operating steps of this Manual. Check in advance on the suitability and condition of personal safety equipment etc. (eyewear, gloves, knee-pads, etc.).



If CONTINUO products are stored at temperatures close to +5°C, before use, we recommend bringing them to a suitable temperature to condition them at a temperature of use of not less than +10°C.



**Surfaces decorated and protected with the transparent finish will be walkable and can withstand light traffic after 24 hours from application of the last layer. Full chemical-physical resistance will be reached after about 5 days. During this period, to avoid possible aesthetic alterations to the surface, do not cover it with sheets or cardboard.**

### 6.1 CONTINUO PRODUCTS

#### CONTINUO LEVEL\_ZERO

- Nature of the Binder: Portland cement, additives and synthetic resins.
- Appearance: grey powder.
- Specific weight of the ready-for-use leveller: 2.0 approx. kg/l
- Working time: about 30 minutes at 20°C, RH=60%.

**Mixing ratio:** 25 kg of LEVEL\_ZERO CONTINUO + 4 - 4.2 l of clean water.

Do not exceed the recommend amounts to avoid segregation during the setting time.

**Mix preparation:** Pour the water for the mix into a clean pot. Slowly add CONTINUO LEVEL\_ZERO to the water using a mechanical spiral mixer.

**Mixing time:** normally three minutes is enough for complete mixing. The mixture obtained must provide a uniform, thixotropic and lump-free mix.

**Pot life:** Use the mix within about 30 minutes, after which the mix - even though it is still usable - loses its workability when spreading. Spread and distribute the mix quickly using a steel spatula to distribute, and pass with a toothed steel spatula. You can use a square- or V-tooth spatula, making semicircular movements, trying to reduce defects when recovering the leveller.



To avoid highlighting marks of recovery between the application of the various pastes, we recommend applying CONTINUO LEVEL\_ZERO in the shortest time possible to ensure maximum mixture spreading. We recommend covering again using a bubble-breaking roller and/or pin roller. This helps to reduce/eliminate the captured air and allows optimization of the applied layer, guaranteeing best surface uniformity.



**If necessary, a second layer of LEVEL\_ZERO CONTINUO can be applied over the first. Before applying a second layer of CONTINUO LEVEL-ZERO leveller, to avoid the possible subsequent formation of small craters on the surface, apply a layer of CONTINUO LINK two-component, water-thinnable, transparent epoxy with a high penetrating and consolidating power, to be used prior to dilution with water of 200% in weight.**

**Do not add more water to lengthen the Pot-life.  
For other types of screed such as those based on calcium sulphate CA or magnesite MA, we recommend contacting our technical support team.**

## CONTINUO BASE

- Binder nature: cement and synthetic resins.
- Specific weight of the ready-to-use leveller: 1.6 approx. kg/l
- Appearance: white powder
- Max. aggregate size: <0.75 mm
- Pot-life: 60 minutes at 20 °C, RH=60%.
- Pot life: Use the mix within about 60 minutes.

**Mixing ratio:** 25 kg CONTINUO BASE + 5-6 l clean water

**Mix preparation:** pour the water for the mix into a clean pot. Slowly add water to CONTINUO BASE, mixing with mechanical spiral mixer.

**Mixing time:** normally three minutes is enough for complete mixing. The mixture obtained must provide a uniform, thixotropic and lump-free mix.

To make it even, manually mix only for small quantities of product, maximum 5 kg.

**Pot life:** Use the mix within about 60 minutes after which the mix - even though still usable - loses its workability when spreading.

Do not add more water to lengthen the Pot-life.

## CONTINUO EPOXY COMBO

- Nature of the binder: Epoxy resin and specific hardener
- Solvent: water
- Density UNI EN ISO 2811-1:
- Component A=1.08±0.05 kg/l.
- Component B=1.04±0.05 kg/l.
- Pot life: Use the mix within about 30 minutes

**Mixing ratio:** 1.6 l of CONTINUO EPOXY COMBO A Component + 0.8 l of CONTINUO EPOXY COMBO B Component + 3 - 3.5 l of water + 25 kg of CONTINUO BASE.

**Mix preparation:** pour EPOXY COMBO A + EPOXY COMBO B into a clean pot; mix manually or with a mechanical spiral mixer at slow speed. Add water and with a mechanical spiral mixer at moderate speed slowly adding CONTINUO BASE.

**Mixing time:** normally three minutes is enough for complete mixing. The mixture obtained must provide a uniform, thixotropic and lump-free mix.

To make it even, manually mix only for small quantities of product, maximum 5 kg.

**Pot life:** Use the mix within about 30 minutes after which the mix - even though still usable - loses its workability when spreading.

Masking tape or protective films must be removed in the first time of hardening of the epoxy skim coat; after complete hardening, removal is extremely difficult.



**Do not add more water to lengthen the Pot-life.**

**To avoid anomalies during the setting time, do not exceed the indicated amount of water. For other types of screed such as those based on calcium sulfate CA or magnesite MA, we recommend contacting our technical support team.**

## CONTINUO DECO

### CONTINUO DECO comp A

-Binder type: acrylic copolymer in water emulsion.

-Solvent: water.

-Density UNI EN ISO 2811-1: 1.77±0.05 kg/l

Pot life: approximately 120 minutes

### CONTINUO DECO comp B

-Binder nature: cement and aggregates.

-Appearance: white powder.

Mixing ratio by weight: 15 kg of DECO A + 5 kg of DECO B.

**Mixing ratio by weight:** 15 kg of DECO CONTINUO A + 5 kg of DECO CONTINUO B.

**Mix preparation:** only immediately before application on site, add a 5 kg pot of CONTINUO DECO A to each 15 kg pot of CONTINUO DECO A. The addition of the powder components CONTINUO DECO A and B must be gradual and carried out with a drill equipped with a whip. The two components cannot be mixed manually.

**Mixing time:** about three minutes. The mixture obtained must provide a uniform, thixotropic and lump-free mix.

**Pot life:** approximately 120 minutes. The product must not be used beyond this time.

**Thinning:** it is possible to dilute the obtained mixture (15 kg of component A + 5 kg of component B) adding up to 5% of water (1 liter).

**Painting:** we recommend stirring CONTINUO DECO A evenly before painting. Paint CONTINUO DECO A with the MARCROMIE tintometric system. You can stir with a gyroscopic mixer or with a mixing drill.

We recommend finishing each job with materials from the same batch of manufacture. When using different production batches, to avoid slight differences in colour shades, we recommend mixing the different batches together. For works where, due to uncontrollable events, you must continue with a new batch, do not try to join colours on the same surface. Instead, use any interruptions of surface continuity such as moldings, edges, expansion joints, etc.

**Application:** Use STAINLESS STEEL trowel and tools

**Before applying CONTINUO LINK and CONTINUO TOP, clean the surfaces thoroughly and remove any dust residues.**

Before applying the primer, we recommend lightly sanding with a random orbital sander equipped with medium-grain sandpaper (120, 150, 180) depending on how compact you want it to be. Image 2

For natural-looking, smooth and monolithic finishes, we recommend sanding the surfaces with a single brush with a cloth disc (80,120) or a random orbital sander equipped with medium-grain paper (120, 150, 180) depending on the degree of compactness you want. Image 1



Image 1



Image 2

## CONTINUO LINK

- Nature of the binder: Epoxy resin and specific hardener
- Solvent: water
- Density UNI EN ISO 2811-1:
- Component A=1.08±0.05 kg/l.
- Component B=1.04±0.05 kg/l.
- Mixture density (A+B) UNI EN ISO 2811-1: 1,07 ± 0.02 kg/l
- Pot-life of the mixture (A+B): approx. 60 minutes at 20 °C

**Mixing ratio by volume:** 0.500 l of component A + 0.250 l of component B adding 3 l of water (example by weight 100 g comp A + 50 g comp B, adding 600 g of water).

**Mixture preparation:** blend in component A LINK CONTINUO with any sediment. Pour CONTINUO LINK component B into CONTINUO LINK component A and mix manually for about 45-60 seconds.

**Thinning:** dilute the mixture obtained (0.5 l of component A + 0.25 l of component B) by adding 3 l of water.

**Mixture life:** about 60 minutes. It must not be used beyond this time as although the product may still be malleable, using it may affect the final performance of the system.

**Application:** Use medium-hair WOOL BRUSH OR ROLLER.

Edge in with flat brush along the perimeter of the room. Spread CONTINUO LINK using a short-hair wool roller, taking care to cover the entire surface.

When applying CONTINUO LINK ART, to avoid the formation of unsightly lines that are too defined from passing the wool roller, image 1, we recommend applying the product so as not to create geometric rolls (high - low - right - left). It is best to make softly-uneven rolls that follow the look of the spatula to integrate the final aesthetics of the decoration.

Pay particular attention to the corners. It is essential to wait for the drying time before applying the CONTINUO TOP finish.

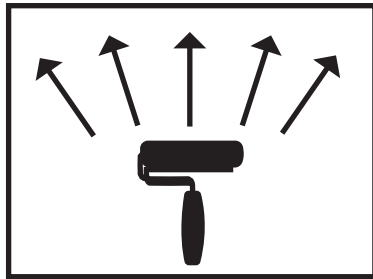

YES

Image 1

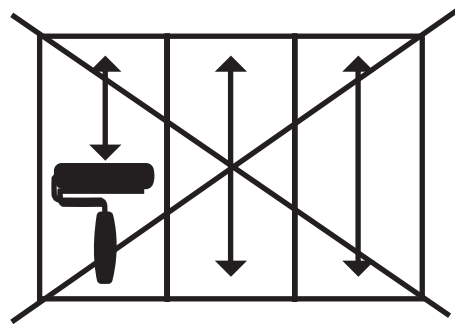

NO

Image 2

## CONTINUO LINK ART

- Nature of the binder: Epoxy resin and specific hardener
- Solvent: water
- Density UNI EN ISO 2811-1:
- Component A=1.06±0.05 kg/l.
- Component B=1,03±0,05 kg/l.
- Mixture density (A+B) UNI EN ISO 2811-1: 1,05 ± 0.02 kg/l
- Pot-life of the mixture (A+B): approx. 60 minutes at 20 °C

**Mixing ratio by weight:** 0.5 l of component A + 0.35 l of component B adding 2.1 l of water (example in weight 100 g comp A + 70 g comp B) adding 425 g of water.

**Mixture preparation:** blend in CONTINUO LINK ART component A with any sediment. Pour CONTINUO LINK ART component B into CONTINUO LINK ART component A and mix manually for about 45-60 seconds.

Thinning: dilute the mixture obtained (0.5 l of component A + 0.35 l of component B) by adding 2.1 l of water.



**Mixture life:** approximately 60 minutes. It must not be used beyond this time as although the product may still be malleable, using it may affect the final performance of the system.

**Application:** Use medium-hair WOOL BRUSH OR ROLLER. In applications where maximum performance in water resistance must be guaranteed (e.g. shower cubicles) after appropriate dilution, we recommend applying CONTINUO LINK ART using only the brush. Edge in with a flat brush around the perimeter of the room. Spread CONTINUO LINK ART using a medium-hair wool roller, taking care to cover the entire surface. Pay particular attention to the corners.

When applying CONTINUO LINK ART, to avoid the formation of unsightly lines that are too defined from passing the wool roller, image 2, we recommend applying the product so as not to create geometric rolls (high - low - right - left). It is best to make softly-uneven rolls that follow the look of the spatula to integrate the final aesthetics of the decoration. (Image 1 see previous image)

It is essential to wait for the drying time before applying one of the CONTINUO TOP or CONTINUO TOP ART finishes.

## CONTINUO TOP

-Nature of the binder: dispersion of modified aliphatic polyurethane.

-Solvent: water

-Drying (at 25 °C and 65% relative humidity): to the touch in 30 min.; can be painted over after 4 hours.

-Gloss level UNI EN ISO 2813:

>85, reading angle of 60° **TOP GLOSSY**

20 ± 2, reading angle of 60° **TOP SATIN**

10 ± 2, reading angle of 85° **TOP MATT**

The CONTINUO TOP comp A finishes are formulated to use the same CONTINUO comp B hardener.

Mixing ratio: 2.5 l of component A + 0.75 l of component B (10 parts of component A + 3 parts of component B). The mixture (A+B) obtained must be used with dilution by weight - volume 0 - max 10%. Excessive dilution of the mixture alters the final performance of the CONTINUO TOP finish.

(10 parts volume of component A + 3 parts volume of component B)

(example in weight 100 g comp A+ 30 g comp B).

The CONTINUO TOP comp A finishes are formulated to use the same CONTINUO comp B hardener.

**Mixing ratio:** 2.5 l component A + 0.75 l component B (10 parts component A + 3 parts component B). The mixture (A+B) obtained must be used with a dilution by weight - volume 0 - max 10%. Excessive dilution of the mixture alters the final performance of the CONTINUO TOP finish.

**(10 parts volume of component A + 3 parts volume of component B)**

**(example in weight 100 g comp A+ 30 g comp B)**

**Mixture preparation:** manually blend in CONTINUO TOP- TOP ART comp A with any sediment. Pour CONTINUO TOP comp B into the relative CONTINUO TOP comp A and mix manually for about 45-60 seconds. You can mix with a mixer-drill equipped with a propeller with slow-stir, for a maximum of 1 minute.

**Thinning:** dilute the mixture obtained (2.500 l of component A + 0.750 l of component B) adding 0.300-0.400 l of water, max. 13% by weight.



**Mixture life:** approximately 60 minutes. The product must not be used beyond this time. Do not intervene on any increase in viscosity by further diluting the product with water.

**Application:** Use medium-hair WOOL BRUSH OR ROLLER.

To obtain an optimal surface evenness and drying uniformity, avoid application under direct sunlight. If there are large glass surfaces, screen the windows. We recommend avoiding direct sunlight.

Edge in with a flat brush around the perimeter of the room. Spread CONTINUO TOP using a medium-hair wool roller, taking care to cover the entire surface.

Pay particular attention to the corners.

When applying CONTINUO TOP, to avoid the formation of unsightly lines that are too defined from passing the wool roller, image 2, we recommend applying the product so as not to create geometric rolls (high - low - right - left). It is best to make softly-uneven rolls that follow the look of the spatula to integrate the final aesthetics of the decoration.

The final protection can be modulated in functionality and appearance by using one of the 3 degrees of gloss finishes. The use of CONTINUO TOP paints guarantees maximum technical performance without compromising the system's appearance refinement.

High chemical and mechanical resistance; suitable for domestic and commercial use.

**With finishes made with CONTINUO TOP - MAT effect, where you want maximum resistance to liquid substances, we recommend applying a layer of CONTINUO TOP SATIN over the primer and finish with a layer of CONTINUO TOP MATT.**

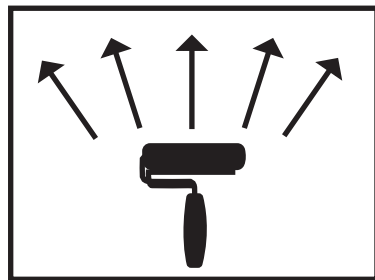

YES

Image 1

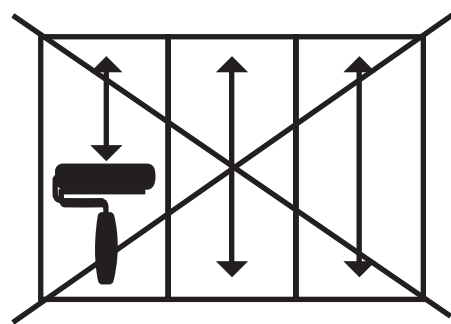

NO

Image 2

## CONTINUO TOP ART

-Nature of the binder: dispersion of modified aliphatic polyurethane.

-Solvent: water

-Gloss level UNI EN ISO 2813:

20 ± 2, reading angle of 60° **TOP SATIN**

4 ± 2, reading angle of 85° **TOP MATT**

**TOP ART SATIN Comp A: Psp 1.05**

**Mixture preparation: 2.5 l of component A + 0.75 l of component B  
(in volume 10 parts of component A + 3 parts of component B)**

(example in weight 100 g comp A+ 30 g comp B)

The mixture (A+B) obtained must be used with a dilution by weight - volume 0-max 15%).

Excessive dilution of the mixture alters the final performance of the CONTINUO TOP finish.

**TOP ART: MATT Comp A: Psp 1.20**

Mixture preparation: 2.5 l of component A + 0.75 l of component B

**(10 parts volume of component A + 3 parts volume of component B)**

**(example in weight 120 g comp A+ 30 g comp B.**

The mixture (A+B) obtained must be used with a dilution by weight - volume 0 - max 10%).

Excessive dilution of the mixture alters the final performance of the CONTINUO TOP finish.

The CONTINUO TOP ART comp A finishes are formulated to use the same CONTINUO comp B hardener.

**Mixture preparation:** manually blend in CONTINUO TOP ART comp A with any sediment. Pour CONTINUO TOP comp B into the relative CONTINUO TOP comp A and mix manually for about 45-60 seconds. It is possible to mix with a mixer-drill equipped with a propeller with slow-stir, for a maximum of 1 minute.

**Mixture life:** approximately 60 minutes. The product must not be used beyond this time. Do not intervene on any increase in viscosity by further diluting the product with water.

**Application:** to obtain an optimal surface evenness and drying uniformity, avoid application under direct sunlight. If there are large glass surfaces, screen the windows. We recommend avoiding direct sunlight.

In applications where maximum performance in terms of water resistance must be guaranteed (e.g. shower cubicles), we recommend applying the first layer of CONTINUO TOP ART after appropriate dilution, using the brush only.

Application with a brush exerts a greater force, helping the penetration and saturation of the micro pores into the support surface.

When applying CONTINUO TOP ART, to avoid the formation of unsightly lines that are too defined from passing the wool roller, we recommend applying the product so as not to create geometric rolls (top - bottom - right - left).

(image 2) it is best to make softly uneven rolls that follow the form of the spatula, to integrate the final aesthetics of the decoration. (Image 1)

The final protection can be modulated in functionality and appearance by using one of the 2 degrees of gloss finishes. The use of CONTINUO TOP paints guarantees maximum technical performance without compromising the system's appearance refinement.

High chemical and mechanical resistance; suitable for domestic and commercial use.



**With finishes made with CONTINUO TOP ART - MAT effect, where you want maximum resistance to liquid substances, we recommend applying a layer of CONTINUO TOP ART SATIN over the primer and finish with a layer of CONTINUO TOP ART MATT.**

**The CONTINUO TOP ART comp A finishes are formulated to use the same CONTINUO comp B hardener.**

## 6.2 COMPLEMENTARY PRODUCTS

### PRO LINK

Product preparation: stir the product manually before use.

- Equipment: brush, roller.
- Stir the product before application.
- Thinning: ready to use, or max 10% with water.
- Number of coats: 1 coat.
- Clean the equipment with water immediately after use.
- Indicative covering capacity: 15-20 sq.m/l. Given the particular type of surface already coated, we recommend making a practical test on the specific background support to determine the consumption.

### ATOMO

Product preparation: dilute the product with clean water. The thinning varies according to the type of background to cover.

- Equipment: brush, roller.
- Stir the product before application.
- Thinning: 50 to 100% with water.
- Number of coats: 1 coat.
- Clean the equipment with water immediately after use.
- Indicative covering capacity: 15-18 sq.m/l.

### Fibre glass mesh with anti-alkali treatment

>70 < 90 g/m<sup>2</sup> with mesh widths between 3.5 mm and 4.5 mm.

**How to lay the mesh:** after placing the first strip of mesh, repeat the operation by placing the two edges of the net side by side. Take care not to overlap them to avoid unsightly lines which could become evident even after a long time. Cover the entire surface with care, integrating any deficiencies to avoid detachments or imperfections appearing even after some time from the application.

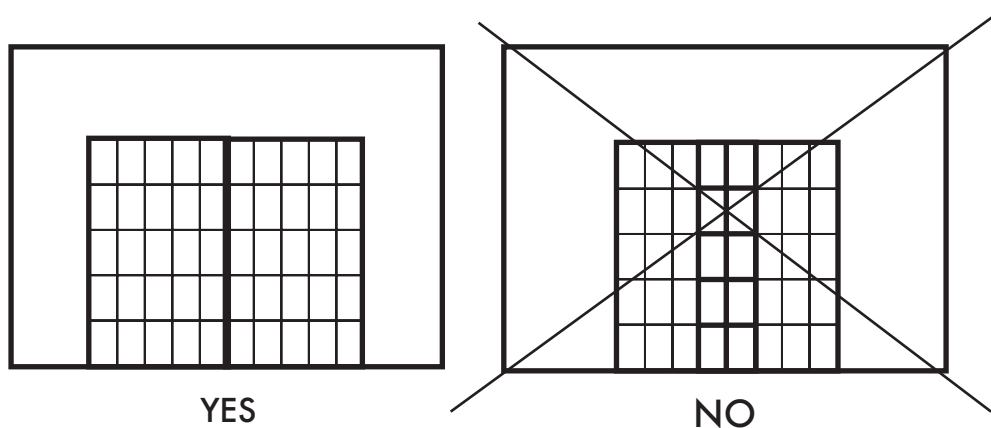

## 7\_INDICATIVE COVERING CAPACITIES

The declared covering capacities are indicative and may vary depending on the state of the support and the type of site. For very large surfaces we recommend checking the actual yield with a preliminary test on the specific substrate.

- **CONTINUO LEVEL\_ZERO** (referred to the powder): 7-8 kg/m<sup>2</sup> per 5 mm thickness, about 4 m<sup>2</sup> per bag per 5 mm thickness.
- **CONTINUO BASE** (referred to powder): 1.5-2.5 kg/m<sup>2</sup>, in the two layers, depending on the type of work and the state of the support, about 15 m<sup>2</sup> per bag for 2 layers.
- **CONTINUO EPOXY COMBO**: 2.0-2.5 kg/m<sup>2</sup> per coat, appropriately mixing with CONTINUO BASE and diluted, approx. 14 m<sup>2</sup> per bag for 2 layers.
- **CONTINUO DECO**: 1.2-1.5 kg/m<sup>2</sup> in two coats, depending on the type of work and condition of the support. For each additional layer, consider another use of 0.3 g / 0.4 g m<sup>2</sup> approx. 15 m<sup>2</sup> per bag for 2 layers.
- **CONTINUO LINK**: 60-70 m<sup>2</sup> per layer with a pot suitably mixed and diluted (A+B)
- **CONTINUO LINK ART**: 35-40m<sup>2</sup> per coat with a pot suitably mixed and diluted (A+B).
- **CONTINUO TOP**: 7-8 m<sup>2</sup>/l in both layers, approx. 25 m<sup>2</sup> per A+B pack for 2 layers.
- **CONTINUO TOP ART**: 7-8m<sup>2</sup>/l in both layers, approx. 25 m<sup>2</sup> per A+B pack for 2 layers.

## 8\_TECHNICAL SPECIFICATIONS AND USE LIMITS

### 8.1 BACKGROUND SUPPORT

The support must be carefully examined and prepared. Given the wide possibility of applications with the CONTINUO system on various types of substrate, depending on its nature and characteristics, carefully evaluate before applying.



**Ground substrates, ventilated under-floor cavities, open porch areas, must be insulated from their support surface with an effective and durable waterproofing, and a water barrier to allow application of the CONTINUO systems.**

Always check the temperature of the support to ensure correct hardening of the products.

Caution: air temperature is not a significant enough parameter.

The temperature of the substrate must never be lower than +8 °C. Near the minimum temperature or with high relative humidity, we recommend ventilating the rooms to improve product drying.

If, when applying, you have any doubt about the moisture content of the substrate, carry out an instrumental check with a hygrometer.

The use of a hygrometer with contact probe measurement may be enough. If working on newly-manufactured screeds and for large surfaces, a direct measurement on the material (e.g. carbide hygrometer) is more reliable. It is customary to work with humidity below 4%.



If you do not have suitable equipment, you can make simple tests to assess whether the support has the correct humidity for applying one of the CONTINUO systems. Apply a transparent polyethylene sheet on the surface, taking care to cover at least 1 m<sup>2</sup>. Seal around the perimeter with a tarpaulin adhesive tape and check the extent of internal condensation after 24 hours.

Make sure there are no traces of dirt (grease, oil, chemicals) and remove any in order to ensure adhesion of the CONTINUO system to the substrate and avoid phenomena, even if only partial, of peeling or detachment.

## 8.2 CONCRETE SURFACES

Normally, concrete is a uniform casting reinforced with electro-welded mesh that prevents the formation of cracks and sags.

Check the concrete slabs made against the ground: they must be insulated with an effective and durable waterproofing and a humidity barrier in order to prevent water rising through capillary action.

Large surfaces and concrete floors are generally not continuous. When creating these types of surfaces, joints are made during work. These meet purely technical rules, which depend on their type. The joints are divided into Static and Dynamic Joints; for this purpose, please refer to this manual at point 8.7 Joints. The surface must be free of grease, oil or aggressive chemicals. Carefully clean any distribution joints or cracks by brushing, sanding or grinding.

## 8.3 CERAMIC, PORCELAIN, STONE MOSAIC AND SIMILAR TILED SURFACES

The surface must be carefully examined to check the degree of adhesion of the tiles, also by tapping them. Remove any non-adherent portions.

As an adhesion bridge, use the product Pro Link as indicated in 6.2 Complementary products. It is possible to scrub the horizontal and vertical surfaces using a random orbital sander with a vacuum cleaner and diamond wheel (image 4/5), until the surface layer is affected. Pay particular attention to corners, and hard-to-reach areas. Then, carefully clean the roughed surface using a vacuum cleaner, avoiding dust or particles depositing that could cause detachment.

Any lackings must be filled with a cementitious skim coat such as BETOXAN 300 or similar. Apply a first layer of the Pro Link adhesion bridge as indicated in point 6.2 Complementary products.

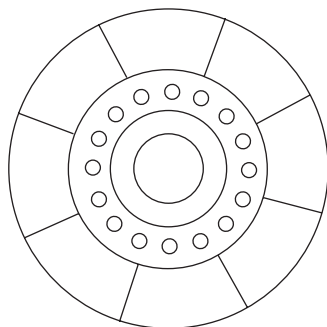

Image 4



Image 5



## 8.4 SCREEDS WITH UNDER-FLOOR HEATING/COOLING

There is no one type of radiant system for underfloor systems. A distinction is to be made according to the type of intervention (whether new building or a renovation), and according to the type of traditional heating system with heating fluid (high- or low inertia) or electric radiant, consisting of a mat made of a fibre-glass mesh that serves as a support for the thermal carbon-fibre conductors, associated with a thermal insulation band to reduce downward heat-loss.



**Generally speaking, the screed on which the decoration is to be carried out with the CONTINUO system must be 'mature'. It is a good rule to run a progressive cycle of the system heating, to verify the system and stabilise the support, so that the surface becomes suitable for applying the CONTINUO system.**

Before laying the CONTINUO system, the screed must always be dry, even and compact. The surfaces' perimeter must have a compressible strip that allows for the screed to expand. As well as determining the durability and efficiency of the technological part of the system, the correct laying of the radiant screed has a significant impact on the aesthetic quality and durability of the decorative work.

**CONTINUO systems are not suitable for use with traditional under-floor heating (heating fluid) with a minimum screed thickness above the radiant elements of less than 30 mm.**

**The CONTINUO systems are not suitable for use where there is electric radiant heating with a minimum screed thickness above the radiant elements of less than 20 mm.**

## 8.5 TRADITIONAL SCREEDS

The CONTINUO systems can be applied to various types of traditional screed.

- screeds of sand and cement, or of sand and binder specific for screeds;
- prepackaged ready-made screeds;
- self-levelling screeds in sand and cement.

Before proceeding, make sure the screed is in good condition and evenly flat.

If the screed is very compact and not very absorbent, you can scrub the surface with a single brush or a random orbital sander, with 24/36 grit tarpaulin paper.

For very chalky screeds, consolidate with CONTINUO LINK two-component, water-dilutable, transparent epoxy product with a high penetrating and consolidating power. Use it after diluting with water of 200% by weight.

Carefully clean the entire surface to be decorated with a vacuum, avoiding the deposit of dust

## 8.6 FLATNESS

For a successful application, it is important to work on surfaces that are well-flat. The surface must be carefully examined to check the degree of adhesion of the tiles, also by tapping them. Remove any non-adherent portions. Check support flatness with a stave. If there are flatness defects and differences in level between adjacent tiles, we recommend mechanically sanding the protruding parts with a random orbital sander fitted with a diamond grinding wheel with a vacuum cleaner Image 4/5 until the surface layer is levelled. Pay particular attention to corners and hard-to-reach areas. Then, carefully clean the roughed surface using a vacuum cleaner, avoiding dust or particles depositing that could cause detachment.

Where necessary, it will be possible to intervene and fix using a self-levelling cement-based screed.

When there are large variations in flatness with respect to the reference level, other solutions capable of restoring flatness within the normal site tolerances must be found.

## 8.7 JOINTS

Large surfaces and concrete floors are generally not continuous. When working with these surfaces, at the time of application, joints are made. These meet purely technical rules, depending on type. The joints are divided into Static and Dynamic joints. Static joints are made immediately after laying the cement with a mechanical cut of up to 1 cm in depth; they can be covered. Their function is to avoid tensions during the setting and hardening, and are easily recognizable thanks to the typical distribution grid that they create on the concrete surface with a length of between 3 and 5 m. After the hardening phase, normally no less than 12 months, they lose their technical function and can, where required, be closed.

From a functional point of view, instead, the Dynamic joints must remain free to absorb any structural movement. They must never be joined or covered.

It is not possible, therefore, to cover the construction joints made to delimit the various castings which, in these cases, are as deep as the entire thickness of the floor. They can be closed with metal systems or sheet metal flaps.

## 8.8 SHOWER CUBICLES

The CONTINUO ACTIVITY and LOUNGE systems can also be applied inside shower cubicles. Before applying, check that the surfaces of the wall and floor are integral and waterproof. If the surface is not integral, prepare with suitable waterproofing products following the normal procedures used for laying ceramic, stone or similar materials.

Check for the presence and condition of the waterproofing in the vicinity of the wells and shower drain.

Before working with the CONTINUO ACTIVITY, LOUNGE systems, take care of the preparation of the floor-to-wall connection surfaces and the correspondence with the drains.

Before implementing, check there is a suitable slope for water drainage. The intervention with the CONTINUO system must not alter the existing slope in order to guarantee water drainage. **After decorating with CONTINUO DECO, apply CONTINUO LINK or LINK ART with a brush, making sure the entire surface and the floor-wall connection areas are impregnated.**



**In the case of finishes made with CONTINUO TOP ART MATT where maximum resistance to liquid substances is required, a first layer of CONTINUO TOP ART SATIN must be applied over the primer and finished with a second layer of CONTINUO TOP ART MATT.**

The final protection with one of the CONTINUO TOP ART finishes will ensure effective protection.

**After the appropriate dilution, apply the first layer of CONTINUO TOP ART using only the brush.**

For works in this context, we recommend applying an additional layer of one of the CONTINUO TOP ART finishes.

After drying, seal with a specific sealant at the drain grate on the floor.



**End-of-work checks: at least 24 hours after completion, we recommend performing a water-tightness test. Wet the entire decorated surface using the shower head with water at room temperature and allow to stand for 30 minutes. Any micro craters found (the amount of which cannot be such as to compromise the aesthetics or the use of the surfaces) can be remedied by going over the affected area with a brush with the CONTINUO LINK ART primer thinned as described in point 6 PREPARATION AND USE OF PRODUCTS**

Inside shower cubicles where there are micro infiltrations of water or humidity after use, you can restore water-repellency by using H-REP SILOSSANICO, spreading it in a thin layer with a cloth or sponge on the surface to restore. H-REP SILOSSANICO is a water-repellent, water-dilutable protective product based on siloxanes, which are non film-forming. It very quickly develops surface water repellency, drastically reducing surface water-absorption. H-REP SILOSSANICO does not alter the original appearance of the CONTINUO finish.

## 8.9 SURFACE SLIPPERINESS

Slip resistance is one of the requirements for commercial building work as a slippery surface is considered an architectural barrier that makes normal walking difficult.

For decorative systems made on-site, as in the case of CONTINUO decorative systems, or for resin flooring, there are currently no specific reference standards referred to flooring.

The measurement of the coefficient of friction or slip resistance in the EU era and in developed countries has not been approached in a uniform way. A picture emerges which is far from unequivocal, resulting in multiple test methods - also very different from each other - that are not directly comparable. One of the most widely-used methods of slipperiness testing is the foot ramp, described in DIN 51130, where slipperiness is measured and classified using the indexed scale R (e.g. R9 - low slip-resistance - to group R13 - high slip-resistance).

For Italy, Ministerial Decree 236 of 1989 establishes generally that a floor has anti-slip properties when the friction coefficient measured on the floor:

- For leather slipping element on a dry floor,  $\mu > 0.40$
- For rubber slipping element on a wet floor,  $\mu > 0.40$

The slip resistance test reports of the CONTINUO systems are available on request.  
Main reference standards for slipperiness:

- BCRA test (Min Dec. 236/89): determination of the average coefficient of friction ( $\mu$ ) under conditions: leather on dry - rubber on wet.
- BS 7976-2:2002: "Pendulum Testers. Part 1: Specification". PTV in dry and wet conditions
- DIN 51130 (06/2004): "Testing of floor coverings. Determination of the anti-slip property - Workrooms and fields of activities with slip danger, walking method - Ramp test". Determination of the total acceptance angle (mean value)
- EN 13036-4 (October 2011 edition). Method for determining the surface adhesion of road and airport pavements, using the arm of a pendulum.
- UNI EN 14041:2018. Floor coverings that are resilient, textile, laminate and multilayer-modular. Essential characteristics
- BS 7976-2:2002: "Pendulum Testers. Determination of the average slip angle; Part 1: Specification". PTV in dry and wet conditions
- DIN 51097 (92): "Testing of floor coverings. Determination of the anti-slip properties; wet-loaded barefoot areas; walking method; ramp test".
- ASTM C 1028-2007 And). Standard Test Method for Determining the Static Coefficient of Friction of Ceramic "Tile and Other Like Surfaces by the Horizontal Dynamometer Pull-Meter Method".

**If you have specific requests regarding friction, please contact the technical service.**

## 8.10 SURFACES & FURNISHINGS

For surfaces decorated with the Continuo system, we recommend the use of transparent silicone plugs and feet normally provided for wooden floors.

The paints of the Continuo system are tested specifically to assess or counteract the transfer of potential soiling substances from the black rubber to the coating. In fact, the chemical mixtures of some components found in rubber can generate unsightly shading by reproducing the shape of the plug/foot on the floor surface. In the event of brownish discolouration, we recommend removing it promptly using a special white buffer sponge (3M -type manufacturer) suitable for cleaning delicate surfaces. The buffer sponge consists of a high-quality synthetic fibre in an open, non-woven structure with non-abrasive cleaning particles. In particularly difficult cases, "magic" sponges used damp, can be of help. They can remove stains and dirt even from delicate surfaces without damaging the surface.

For chairs with casters, to avoid unsightly black streaks, specific soft wheels in transparent polyurethane or silicone are available. Transfer phenomena can also be found recently in areas where rubber wheels of electric scooters and mono-wheelers are permanently stationed. Also in this case, over time, these can release plasticizing substances or other components found in rubber compounds which, in particular conditions, can generate anomalies in the aesthetic appearance. We recommend in these cases that, when shading occurs, to intervene promptly by removing it with a multisurface degreasing detergent for use on surfaces both industrial and in the home that is suitable for removing oil and lubricants, etc.  
Use according to the manufacturer's instructions.

	Problem	What to use	How to intervene	Solution
Chair plugs and feet	Direct colour transfer	"Magic" sponge or eraser etc.	With "magic" sponge or eraser etc.	Replace black rubber stoppers with silicone stoppers for parquet flooring.
Chairs with casters	Black streaks	"Magic" sponge or white eraser etc	With "magic" sponge or white eraser etc.	Replace black rubber rollers with rubber or polyurethane rollers for parquet floors.
Macchie caffè-vino-ecc	Coloured delimited areas	Household Bleach - hypochlorite	Pour a few drops on the stain itself and leave it to work for a few minutes until the stain disappears. Rinse and, if necessary, repeat the operation.	Intervene promptly on the surface.
Coffee and wine stains, etc.	Dark spots	Non-alkaline degreasing detergent	Pour onto a non-coloured wool or cotton cloth, cover the area and leave it to work for no longer than 1 hour; rinse and then repeat if necessary.	Intervene promptly on the surface.
Limescale deposits	Delimited areas with white deposit	White-wine vinegar	Mix two parts white-wine vinegar, one part warm water. Spray on the walls of the shower cubicle and scrub with a gentle sponge, or a "magic" sponge.	Intervene promptly on the surface.
Mould growth	Delimited areas with formations of brown or black spots	COMBAT 222 or household bleach-hypochlorite	Spray or pour small quantities of product locally onto the stain and leave it to work for up to a maximum of 10 minutes until the stain disappears. Rinse and, if necessary, repeat the operation.	Intervene promptly on the surface.
Micro-infiltrations of water on the walls of the shower box	Delimited areas of darker colour	H-REP SILOSSANICO or CONTINUO LINK ART	Pour a thin amount of product on a white cotton cloth, spread evenly over the surface and allow to absorb. If necessary, repeat wet-on-wet within no longer than 1 hour.	Intervene promptly on the surface.

## 9\_SITE ENVIRONMENTAL CONDITIONS

Surfaces must be protected from frost and big temperature changes throughout application of the cycle. Do not apply when the temperature of the air, support or product is below +10 °C, or above +35 °C, if under direct sunlight, or on heated surfaces (even if already in the shade), or on damp surfaces.

The conditions of the environment and support required to proceed with application are:

- Ambient temperature: Min. +10°C - Max. +35 °C
- Ambient relative humidity: <75%
- Substrate temperature: Min. +10 °C - Max. +35 °C
- Support relative humidity: <4%

Application in conditions different from those described above may cause defects of the chemical-physical properties and of the aesthetic result of the CONTINUO system.



## 9.1 PRODUCT STORAGE



Do not expose the products for long periods to direct heat sources, or to temperatures below +5°C. If the products are stored at temperatures close to +5°C, before use, we recommend bringing them to a suitable temperature to condition them at a temperature of use of not less than +10°C. If stored at temperatures below +10°C, condition the products by placing them in a properly-heated environment.

Do not use a direct heat source, flame, hot body or similar. Low temperatures increase the viscosity in the pot, making it difficult to use, and lengthening or inhibiting drying and curing process of the various products.

Maximum storage temperature +35°C.

Stability in the unopened original containers and at a suitable temperature: 1 year for powder and two-component products, 2 years for paste products.

## 10\_CLEANING AND MAINTENANCE OF THE BACKGROUND SURFACES

Routine surface cleaning is done using normal floor cleaning products.

Do not use highly alkaline or acidic descaling agents as they may affect the surface of the CONTINUO system and compromise its aesthetics. The surfaces show good resistance to a wide variety of substances used widely in home and office environments. It is good practice to avoid prolonged contact with soiling or aggressive substances. Clean the CONTINUO surfaces quickly with water.

For cleaning the black scratches left by heels and tyres, we recommend using specific white buffer sponges (3M -type manufacturer) consisting of a high-quality synthetic fibre in an open non-woven structure with non-abrasive cleaning particles; alternatively, a white eraser can be used. In particularly difficult cases, "magic" wet sponges can help. This type of sponge becomes a sort of very fine, delicate abrasive with a grain that can remove stains and dirt even from delicate surfaces without damaging the surface. They also have the characteristic of wearing out during the cleaning phase, thereby avoiding soiling and dirt-dragging.

In living environments, to clean surfaces you can use DIY solutions based on sodium bicarbonate and vinegar. We recommend not using on surfaces finished with clear paints (resin floors - parquet - CONTINUO) as accidental wrong dosages could be corrosive and alter the protection of the paint.

For routine cleaning of CONTINUO surfaces, in addition to neutral detergents for domestic floors, detergents for varnished and oiled parquet are also suitable. Do not use acidic or acid-buffered de-scaling detergents that are specific for cleaning concrete surfaces.



**In shower cubicles or humid areas where mould is present, COMBAT 222 can be used. The product is applied directly onto the support, left to work for about 10 minutes, then the surfaces are thoroughly rinsed with water. - Where there is a lot of mould/mildew, repeat the treatment several times until the surfaces are fully restored.**

**Do not use industrial brushing machines and detergents intended for cleaning ceramic or stone floors, as they may affect their performance and aesthetics.**

**In general, surfaces covered with CONTINUO systems can be washed with suitable non-aggressive (neutral) detergents, in cold or moderately-hot water (never exceed 40°C, avoiding thermal shocks and steam cleaning).**

If it is necessary to clean the surface from very greasy or particularly stubborn dirt, we recommend using a degreasing detergent recommended by the manufacturer as suitable for use on many surfaces in the home and in industry for removing oil, lubricants, etc. Use according to the manufacturer's instructions. It is always a good rule to intervene promptly on the surface as soon as soiling is noticed.

Maintenance works, especially if found in a portion of the surface, may be visible. We normally recommend using the same CONTINUO TOP or TOP ART finish that was used in the first laying phase. Apply the product with a medium-hair roller. The surface can be walked on after 24 hours.

*made in Italy*



cod. 00357 ed. 04/2022



San Marco Group S.p.A .  
Via Alta, 10, 30020 Marcon (VE), Italia  
T +39 041 4569322 - F +39 041 5950153  
info@san-marco.it  
export@san-marco.it  
www.san-marco.com

